



# PRODUCTS CATALOG

ELECTRICAL ENCLOSURES & MODULAR CABINETS



# 20

[exmweb.com](http://exmweb.com)

## QUICK RELEASE SUBMERSIBLE POLYESTER ENCLOSURES

The 5600 ESPLQW are suited for use indoors or outdoors where corrosion is a problem, to protect the enclosed equipment from water coming from any direction, dust, dirt and oil. The 5600 ESPLQW is made of a polyester and polycarbonate hybrid blend, aesthetically designed and produced exclusively by EXM. It is the material of choice for numerous industrial applications. Its

electrical, chemical and physical properties allow to be used in many environments and for a wide variety of applications. A high quality molded gasket ensures a complete NEMA 6P seal. The cover screws are made of stainless steel. The body of the 5600 ESPLQW enclosures incorporates mounting holes. Enclosures can be completed with an optional 14 GA galva-

nized inner panel, which can be mounted in the rear of the enclosure or on the cover. Inner panels and mounting feet are secured by anti-vibration screws. Quick release latches can be removed and replaced by cover screw inserts.

**NEMA/EEMAC 6P / IP68**

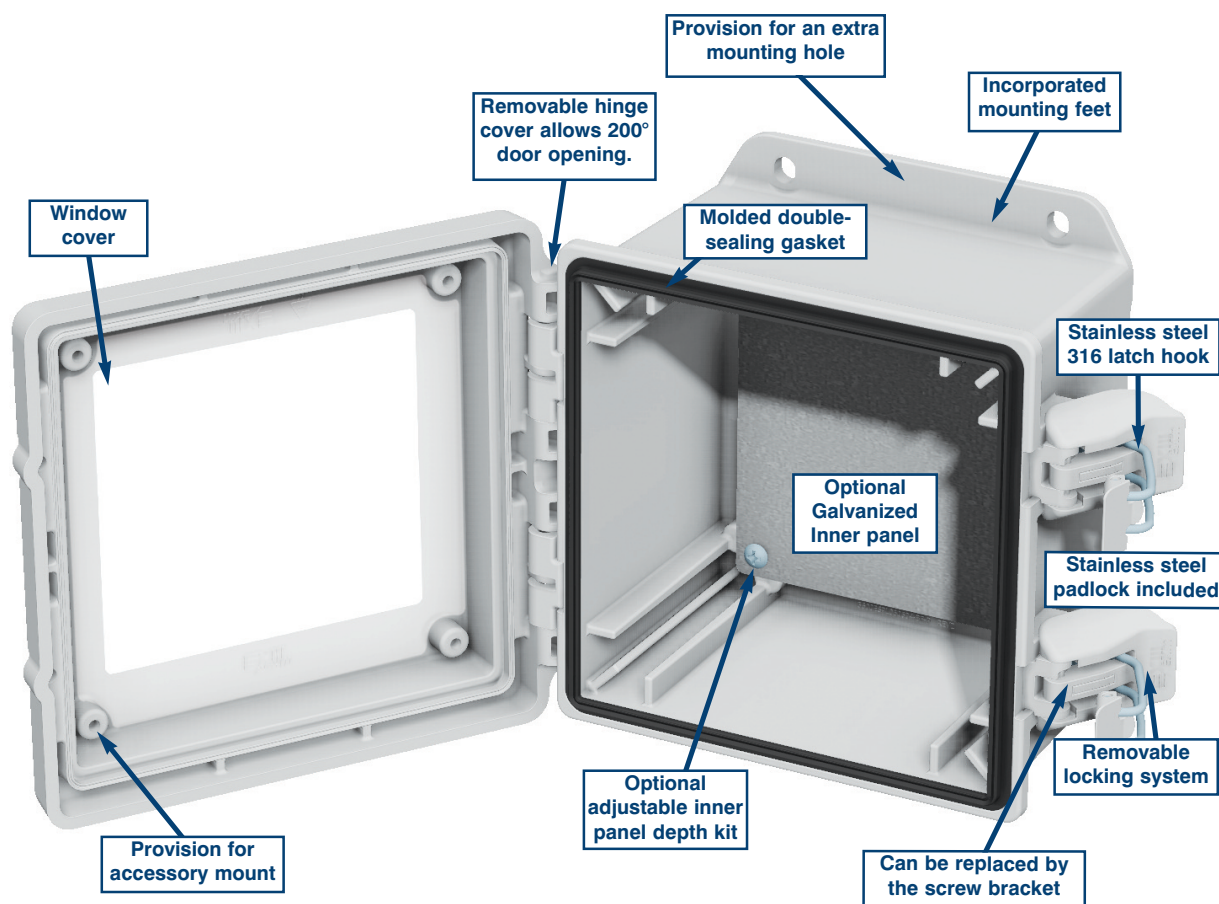

The 5600 ESPLQW  
Available only from EXM

## QUICK RELEASE SUBMERSIBLE POLYESTER ENCLOSURES

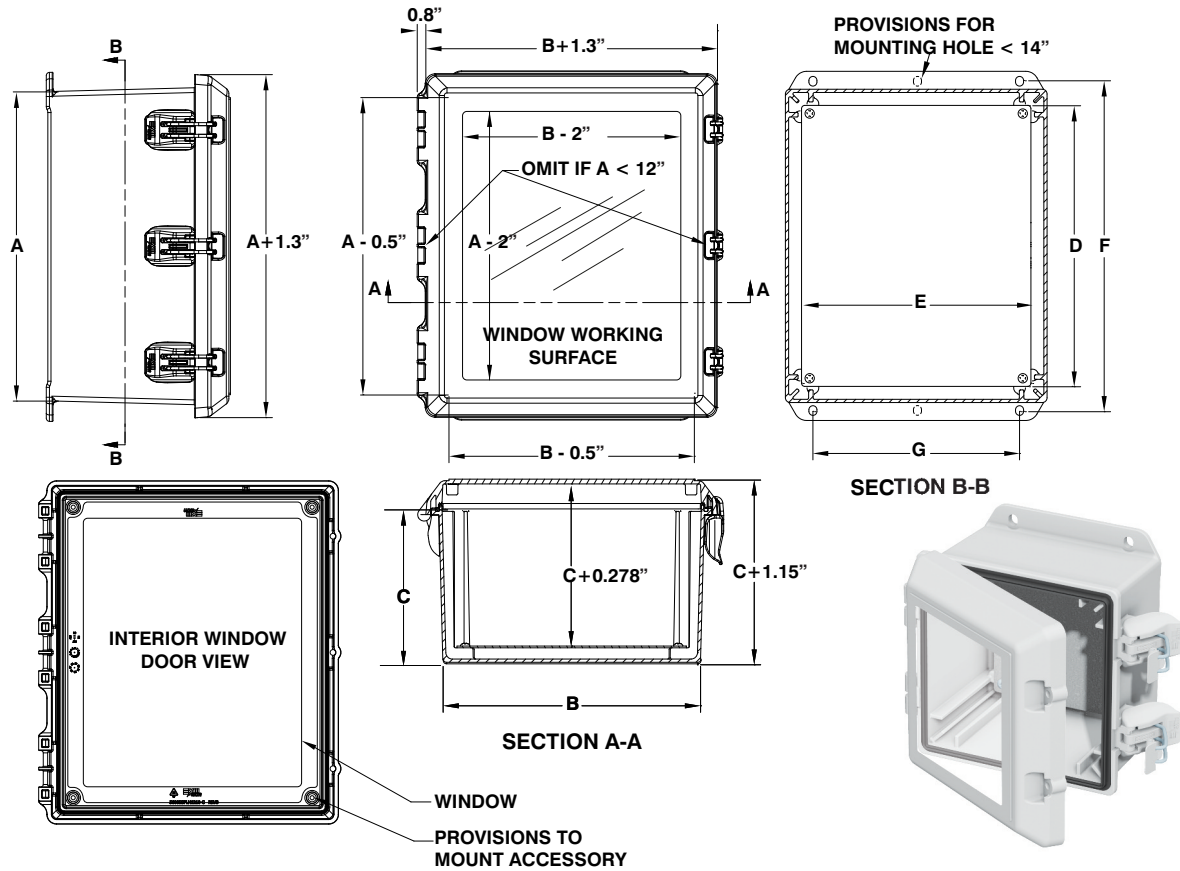

CATALOG NUMBER	DIMENSIONS							EQUIPMENT PANEL FULL	SHIP WGHT LBS.
	A	B	C	D	E	F	G		
5600 ESPLQW060404	6	4	4	4.88	2.88	6.75	2	880 SP0604G	1
5600 ESPLQW060604	6	6	4	4.88	4.88	6.75	4	880 SP0606G	2
5600 ESPLQW080604	8	6	4	6.88	4.88	8.75	4	880 SP0806G	2
5600 ESPLQW080804	8	8	4	6.88	6.88	8.75	6	880 SP0808G	2
5600 ESPLQW100804	10	8	4	8.88	6.88	10.75	6	880 SP1008G	3
5600 ESPLQW101006	10	10	6	8.88	8.88	10.75	8	880 SP1010G	4
5600 ESPLQW121005	12	10	5	10.88	8.88	12.75	8	880 SP1210G	7
5600 ESPLQW121008	12	10	8	10.88	8.88	12.75	8	880 SP1210G	7
5600 ESPLQW121206	12	12	6	10.88	10.88	12.75	10	880 SP1212G	7
5600 ESPLQW141206	14	12	6	12.88	10.88	14.75	10	880 SP1412G	6
5600 ESPLQW141208	14	12	8	12.88	10.88	14.75	10	880 SP1412G	6
5600 ESPLQW161406	16	14	6	14.88	12.88	16.75	12	880 SP1412G	10
5600 ESPLQW161408	16	14	8	14.88	12.88	16.75	12	880 SP1614G	10
5600 ESPLQW161606	16	16	6	14.88	14.88	16.75	14	880 SP1616G	10
5600 ESPLQW161610	16	16	10	14.88	14.88	16.75	14	880 SP1616G	12
5600 ESPLQW201606	20	16	6	18.88	14.88	20.75	14	880 SP2016G	12

CATALOG NUMBER	METRIC DIMENSIONS							EQUIPMENT PANEL FULL	SHIP WGHT LBS.
	A	B	C	D	E	F	G		
5600 ESPLQW060404	152	101	101	124	73	171	51	880 SP0604G	0.45
5600 ESPLQW060604	152	152	101	124	73	171	102	880 SP0606G	0.91
5600 ESPLQW080604	203	152	101	175	124	222	102	880 SP0806G	0.91
5600 ESPLQW080804	203	203	101	175	175	222	152	880 SP0808G	0.91
5600 ESPLQW100804	254	203	101	226	175	273	152	880 SP1008G	1.36
5600 ESPLQW101006	254	254	152	226	226	273	203	880 SP1010G	1.81
5600 ESPLQW121005	304	254	127	276	226	324	203	880 SP1210G	3.18
5600 ESPLQW121008	304	254	203	276	226	324	203	880 SP1210G	3.18
5600 ESPLQW121206	304	304	152	276	276	324	203	880 SP1212G	3.18
5600 ESPLQW141206	356	304	152	327	276	375	254	880 SP1412G	2.72
5600 ESPLQW141208	356	304	203	327	276	375	254	880 SP1412G	2.72
5600 ESPLQW161406	406	356	152	378	327	425	305	880 SP1614G	4.54
5600 ESPLQW161408	406	356	203	378	327	425	305	880 SP1614G	4.54
5600 ESPLQW161606	406	406	152	378	378	425	356	880 SP1616G	4.54
5600 ESPLQW161610	406	406	254	378	378	425	356	880 SP1616G	5.44
5600 ESPLQW201606	508	406	152	480	378	527	356	880 SP2016G	5.44